

EDILIZIA CIVILE

# CANNE FUMARIE Cemento-Argilla



# CANNE FUMARIE

## Cemento – Argilla

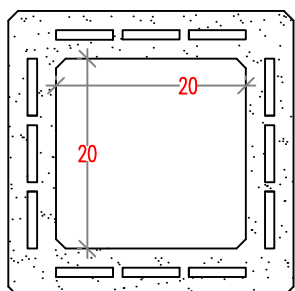

Misure interne nette	20x20 h.25	
Codice: CAN20	Peso	Kg.16
Pezzi su pedana	N. 60	
Pedane su Bilico	N. 24	
COSTO €/Pz.		€/Pz.

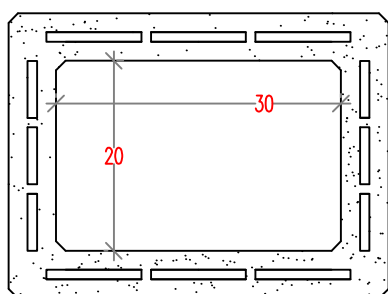

Misure interne nette	20x30 h.25	
Codice: CAN30	Peso	Kg.19.5
Pezzi su pedana	N. 55	
Pedane su Bilico	N. 24	
COSTO €/Pz.		€/Pz.

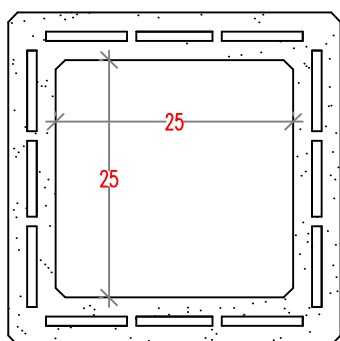

Misure interne nette	25x25 h.25	
Codice: CAN25	Peso	Kg.19
Pezzi su pedana	N. 50	
Pedane su Bilico	N. 24	
COSTO €/Pz.		€/Pz.

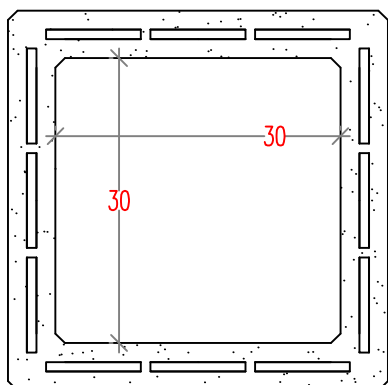

Misure interne nette	30x30 h.25	
Codice: CAN30-	Peso	Kg.28
Pezzi su pedana	N. 30	
Pedane su Bilico	N. 24	
COSTO €/Pz.		€/Pz.